

LFX
 File: LFX.kicad_sch
 NEW_INT

LFX_TABLE
 File: LFX_TABLE.kicad_sch
 FUSE_RELAY_BOX

File: NEW_INT.kicad_sch
 File: FUSE_RELAY_BOX.kicad_sch

NOTES:
 LFX TO BE MODIFIED TO:
 - REMOVE UNUSED WIRES (DEFINED IN LFX TABLE)
 - TERMINATE POWER CONNECTIONS INTO NEW FUSE BOX
 - EXTEND AND TERMINATE WIRES IN BULKHEAD CONNECTOR
 - ADD NEW WIRING FOR FANS AND FLEX FUEL SENSOR

MAKE INTERIOR HARNESS FROM SCHEMATIC

Signal	Description	From
6	Starter Solenoid Crank Voltage	LFX Diagram
23	Generator Field Duty Cycle Signal	LFX Diagram
25	Charge Indicator Control	LFX Diagram
59	A / C Compressor Clutch Supply Voltage	LFX Diagram
100	Battery Pos	Miata
101	Switched Battery Pos (Main Relay)	Miata
102	Switched Battery Pos (Engine Control Relay)	New
103	Switched Battery Pos (Ignition Switch)	Miata
104	Fuel Pump Switched Pos Power	New
105	Cooling Fan Low Speed Pos Power	New
106	Cooling Fan High Speed Pos Power	New
107	Cooling Fan Relay Coil Power	New
108	Fan 1 Pos	New
109	Fan 1 Neg	New
110	Fan 2 Pos	New
111	Fan 2 Neg	New
112	A/C Clutch Signal (Ground = EN)	Miata
113	A/C Refrigerant Pressure Switch	Miata
114	Fuel Pump Coil Pos	LFX Harness
115	Flex Fuel Signal	New
116	Kill Switch Pos	New
117	Kill Switch Neg	New
118	Stock Miata Fuel Pump Control (GND = ON)	Miata
239	MAF_VSS_FPCM	LFX Diagram
331	Oil Pressure Sensor Signal	LFX Diagram
335	Low Speed Cooling Fan Relay Control	LFX Diagram
380	A/C Refrigerant Pressure Sensor Signal	LFX Diagram
410	Engine Coolant Temperature Sensor Signal	LFX Diagram
419	MIL Control	LFX Diagram
428	EVAP Canister Purge Solenoid Control	LFX Diagram
432	Manifold Absolute Pressure Sensor Signal -	LFX Diagram
439	Ignition Voltage	LFX Diagram
440	ECM Battery Backup	LFX Diagram
451	Ground	LFX Diagram
459	A / C Compressor Clutch Relay Control	LFX Diagram
465	Fuel Pump Relay Control	LFX Diagram
469	Manifold Absolute Pressure Sensor Low Reference	LFX Diagram
473	High Speed Cooling Fan Relay Control	LFX Diagram
485	Throttle position Sensor 1 (LSA) **	LFX Diagram
486	Throttle Position Sensor 2 (LSA) **	LFX Diagram
492	Mass Air Flow Sensor Signal	LFX Diagram
496	Knock Sensor Signal (1)	LFX Diagram
581	TAC Motor Control 2 (LSA) **	LFX Diagram
582	TAC Motor Control 1 (LSA) **	LFX Diagram
585	Transmission Oil Temperature Sensor Signal MVS	LFX Diagram
890	Fuel Tank Pressure Sensor	LFX Diagram
1163	APP Sensor 1 Signal 2	LFX Diagram
1162	APP Sensor 2 Signal	LFX Diagram
1164	S - Volt Reference 2	LFX Diagram
1271	Low Reference	LFX Diagram
1272	Low Reference	LFX Diagram
1274	S - Volt Reference 3 (LFX)	LFX Diagram

1310	EVAP Canister Vent Solenoid	LFX Diagram
1470	Brake Booster Pump Motor Supply Voltage	LFX Diagram
1714	Knock Sensor Low Reference (1)	LFX Diagram
1786	Transmission Park / Neutral Signal (1) MYB	LFX Diagram
1840	TCM Control Solenoid (Automatic)	LFX Diagram
1876	Knock Sensor Signal (2)	LFX Diagram
1936	Fuel Level Sensor Signal	LFX Diagram
1937	Fuel Level Sensor Signal	LFX Diagram
2022	Charg Air Cooler Coolant Pump B+	LFX Diagram
2121	Ignition Control (1)	LFX Diagram
2122	Ignition Control (2)	LFX Diagram
2123	Ignition Control (3)	LFX Diagram
2124	Ignition Control (4)	LFX Diagram
2125	Ignition Control (5)	LFX Diagram
2126	Ignition Control (6)	LFX Diagram
2129	Ignition Control Low Reference Bank 1	LFX Diagram
2130	Ignition Control Low Reference Bank 2	LFX Diagram
2139	TCM Fuse 1 (Automatic Transmission)	LFX Diagram
2303	Knock Sensor Low Reference (2)	LFX Diagram
2500	GMLAN Serial Data Bus + (CAN High)	LFX Diagram
2501	GMLAN Serial Data Bus (CAN Low)	LFX Diagram
2700	A/C Refrigerant Pressure SW Reference 3 (LFX)	LFX Diagram
2701	5 - Volt Reference 2 (LSA) **	LFX Diagram
2704	Manifold Absolute Pressure Sensor 5 - Volt Reference 3	LFX Diagram
2705	5 - Volt Reference 1	LFX Diagram
2709	5 - Volt Reference 1	LFX Diagram
2752	5 - Volt Reference 1 (LSA) **	LFX Diagram
2755	Low Reference	LFX Diagram
2760	Intake Air Temperature Sensor Low Reference	LFX Diagram
2761	Coolant Temperature Sensor Low Reference	LFX Diagram
2917	Fuel Rail Pressure Sensor (5) Volt Reference 1	LFX Diagram
2918	Fuel Rail Pressure Sensor Signal	LFX Diagram
2919	Sensor Low Reference	LFX Diagram
3110	Heated Oxygen Sensor High Signal Bank 1 Sensor (1)	LFX Diagram
3111	Heated Oxygen Sensor Low Signal Bank 1 Sensor (1)	LFX Diagram
3113	Heated Oxygen Sensor Heater Low Control Bank 1 Sensor (1)	LFX Diagram
3120	Heated Oxygen Sensor High Signal Bank 1 Sensor (2)	LFX Diagram
3121	Heated Oxygen Sensor Low Signal Bank 1 Sensor (2)	LFX Diagram
3122	Heated Oxygen Sensor Heater Low Control Bank 1 Sensor (2)	LFX Diagram
3200	Barometric Pressure Sensor Signal	LFX Diagram
3201	5V Reference 1	LFX Diagram
3210	Heated Oxygen Sensor High Signal Bank 2 Sensor (1)	LFX Diagram
3211	Heated Oxygen Sensor Low Signal Bank 2 Sensor (1)	LFX Diagram
3212	Heated Oxygen Sensor Heater Low Control Bank 2 Sensor (1)	LFX Diagram
3220	Heated Oxygen Sensor High Signal Bank 2 Sensor (2)	LFX Diagram
3221	Heated Oxygen Sensor Low Signal Bank 2 Sensor (2)	LFX Diagram
3223	Heated Oxygen Sensor Heater Low Control Bank 2 Sensor (2)	LFX Diagram
3630	Throttle Position Sensor (SENT) Signal	LFX Diagram
4801	Direct Fuel Injector (DFI) High Voltage Control Cylinder 1	LFX Diagram
4802	Direct Fuel Injector (DFI) High Voltage Control Cylinder 2	LFX Diagram
4803	Direct Fuel Injector (DFI) High Voltage Control Cylinder 3	LFX Diagram
4804	Direct Fuel Injector (DFI) High Voltage Control Cylinder 4	LFX Diagram
4805	Direct Fuel Injector (DFI) High Voltage Control Cylinder 5	LFX Diagram
4806	Direct Fuel Injector (DFI) High Voltage Control Cylinder 6	LFX Diagram

4901	Direct Fuel Injector (DFI) High Voltage Supply Cylinder 1	LFX Diagram
4902	Direct Fuel Injector (DFI) High Voltage Supply Cylinder 2	LFX Diagram
4903	Direct Fuel Injector (DFI) High Voltage Supply Cylinder 3	LFX Diagram
4904	Direct Fuel Injector (DFI) High Voltage Supply Cylinder 4	LFX Diagram
4905	Direct Fuel Injector (DFI) High Voltage Supply Cylinder 5	LFX Diagram
4906	Direct Fuel Injector (DFI) High Voltage Supply Cylinder 6	LFX Diagram
5007	Reverse Switch Signal MVS +	LFX Diagram
5272	Camshaft Phaser Intake Solenoid (2)	LFX Diagram
5273	Camshaft Position Exhaust Sensor (1)	LFX Diagram
5274	Camshaft Position Exhaust Sensor (2)	LFX Diagram
5275	Camshaft Position Intake Sensor (1)	LFX Diagram
5276	Camshaft Position Intake Sensor (2)	LFX Diagram
5282	Camshaft Phaser Exhaust Solenoid (1)	LFX Diagram
5283	Camshaft Phaser Exhaust Solenoid (2)	LFX Diagram
5284	Camshaft Phaser Intake Solenoid (1)	LFX Diagram
5290	ECM Fuse	LFX Diagram
5291	Odd Cylinder Coil and Injectors	LFX Diagram
5292	Even Cylinder Coil and Injectors	LFX Diagram
5293	Upstream O2 Sensors, Cam Actuators, Evap	LFX Diagram
5294	Downstream O2 Sensors	LFX Diagram
5296	Camshaft Position Exhaust Sensor Low Reference (1)	LFX Diagram
5297	5 - Volt Reference 1	LFX Diagram
5298	Camshaft Position Intake Sensor 5 - Volt Reference 1	LFX Diagram
5299	Camshaft Position Exhaust Sensor Low Reference (2)	LFX Diagram
5300	5 - Volt Reference 1	LFX Diagram
5301	Camshaft Position Intake Sensor Low Reference (1)	LFX Diagram
5302	Camshaft Position Intake Sensor 5 - Volt Reference 1	LFX Diagram
5303	Camshaft Position Intake Sensor Low Reference (2)	LFX Diagram
5380	Brake Position Sensor Signal MYB	LFX Diagram
5381	Brake Position Sensor 5 Volt Reference	LFX Diagram
5514	A/C Refrigerant Pressure Low Reference	LFX Diagram
5985	Serial Data Wake - Lip Signal	LFX Diagram
5991	Powertrain Relay Control	LFX Diagram
6111	Clutch Pedal Position Sensor	LFX Diagram
6270	Crankshaft 60X Sensor Voltage	LFX Diagram
6271	Crankshaft 60X Sensor Signal	LFX Diagram
6272	Crankshaft 60X Sensor Low Reference	LFX Diagram
6321	LFX Diagram	LFX Diagram
6289	Induction Air Temperature Sensor Signal	LFX Diagram
6311	Brake Pedal Switch Signal	LFX Diagram
6354	Output Speed High (Replicated TOS) Input Signal MVS	LFX Diagram
6386	Starter Relay Control	LFX Diagram
6753	Cam Phaser W Return Low Reference	LFX Diagram
6754	Cam Phaser X Return Low Reference	LFX Diagram
6755	Cam Phaser Y Return Low Reference	LFX Diagram
6756	Cam Phaser Z Return Low Reference	LFX Diagram
7300	High Pressure Fuel Pump Actuator Low Control	LFX Diagram
7301	High Pressure Fuel Pump Actuator High Control	LFX Diagram
7348	Vacuum Assist Pump Relay Coil Control	LFX Diagram
7564	Humidity Sensor Signal	LFX Diagram

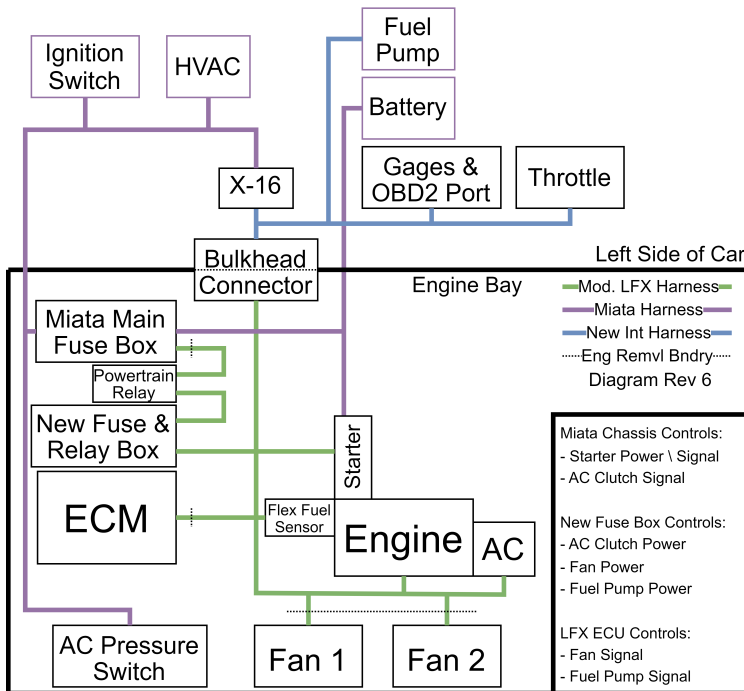

WIRE SIZING CHART
 SOURCE: WAYTEKWIRE.COM
 - SHADED AREA COULD BE 20AWG FOR ELECTRICAL PURPOSES, LISTED AS 18AWG FOR STRENGTH
 - BASED ON MAX 10% VOLTAGE DROP @ 100°F

Total Approx. Circuit Amperes	Wire Gauge (For Length In Feet)											
	3	5	7	10	15	20	25	30	40	50	75	100
1	18	18	18	18	18	18	18	18	18	18	18	18
1.5	18	18	18	18	18	18	18	18	18	18	18	18
2	18	18	18	18	18	18	18	18	18	18	16	16
3	18	18	18	18	18	18	18	18	18	18	14	14
4	18	18	18	18	18	18	18	18	18	16	12	12
5	18	18	18	18	18	18	18	18	18	16	14	12
6	18	18	18	18	18	18	18	16	16	14	12	10
7	18	18	18	18	18	18	16	16	14	14	10	10
8	18	18	18	18	18	16	16	16	14	12	10	10
10	18	18	18	18	16	16	16	16	14	12	10	10
11	18	18	18	18	16	16	14	14	12	12	10	8
12	18	18	18	18	16	16	14	14	12	12	10	8
15	18	18	18	18	14	14	12	12	12	10	8	8
18	16	16	16	16	14	14	12	12	10	10	8	8
20	16	16	16	16	14	12	10	10	10	10	8	6
22	14	16	14	14	12	12	10	10	10	8	6	6
24	14	14	14	14	12	12	10	10	10	8	6	6
30	12	12	12	12	10	10	10	10	10	6	4	4
40	10	8	8	8	8	8	8	8	6	6	4	2
50	8	8	8	8	8	8	8	6	6	2	2	2
100	4	4	4	4	4	4	4	4	2	1	1/0	1/0
150	2	2	2	2	2	2	2	2	1	2/0	2/0	2/0
200	1/0	1/0	1/0	1/0	1/0	1/0	1/0	1/0	1/0	4/0	4/0	4/0

WIRE AREA TO AWG
 FROM CAMARO REPAIR MANUAL PAGE:
 REPAIRING DAMAGED WIRE INSULATION

AWG	Area (mm ²)
1/0	53.5
2	33.6
4	21.1
6	13.3
8	8.36
10	5.26
12	3.31
14	2.08
16	1.31
18	0.82
20	0.52
22	0.33
24	0.2
26	0.13

Sheet: /
 File: harnesses.kicad_sch

Title: OVERVIEW

NB Miata LFX Wiring

Size: A Date: 2023-11-16

victorzaccardo@gmail.com
 KiCad E.D.A. kicad 7.0.6

Rev: 1
 Id: 1/5

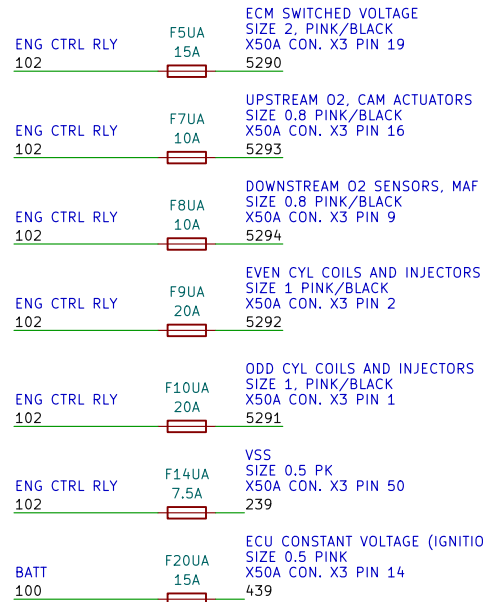

POWER DISTRIBUTION MODULE GEP 72-WAY PDM P/N PDM-S2AC1 DIODE KEY P/N PDM-TK			MINI DIODE WAYTEK P/N 46880	
GAGE	TERMINAL	CABLE SEAL	FUSES RATING	DIGIKEY P/N
22-20	12084201-L	15324983	7.5A	F990-ND
16-14	12077412-L	15324980	10A	F991-ND
12	12129493-L	15324981	15A	F992-ND
			20A	F993-ND
			30A	F995-ND

POWER RELAY

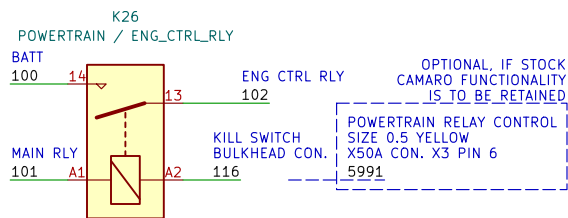

EATON BUSSMANN 37702-1AN0022
CONNECTOR: METRI-PACK 150 2-POSITION WITH SOCKETS
2X 60A JCASE FUSE - WAYTEK 46594
TORQUE RATINGS:
M8 INPUT STUD: 144 IN-LB MAX
M6 OUTPUT STUD: 48 IN-LB MAX
M6 MOUNTING: 48 IN-LB MAX

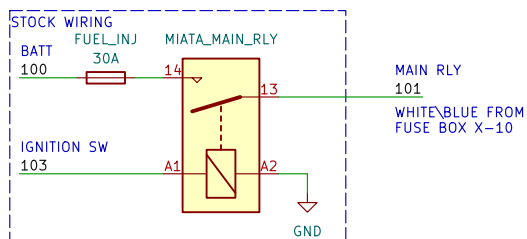

FUEL PUMP

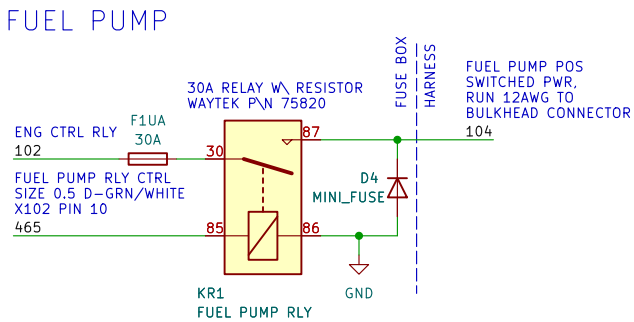

ENGINE COOLING FANS

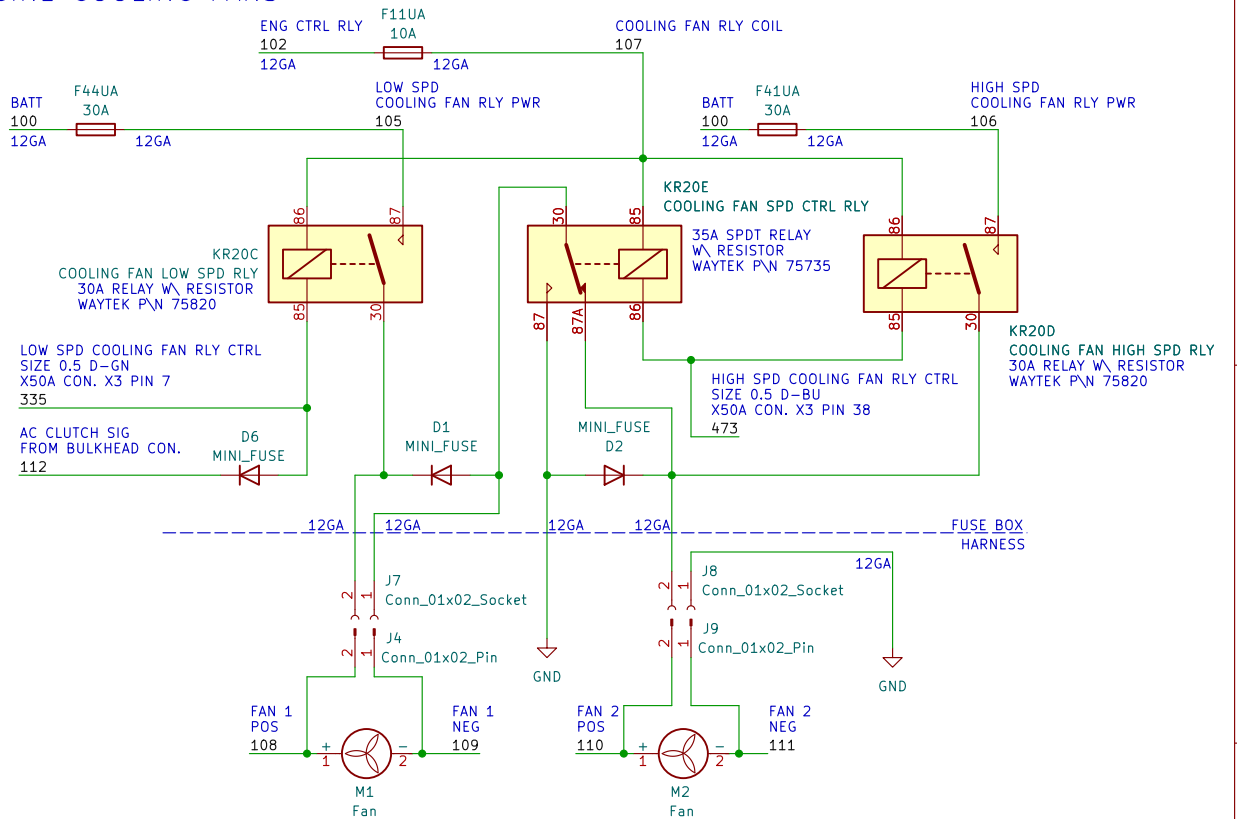

NOTES:
- UNLESS OTHERWISE NOTED, ALL WIRES ARE 20AWG

Sheet: /FUSE_RELAY_BOX/
File: FUSE_RELAY_BOX.kicad_sch

Title: NEW FUSE & RELAY BOX

NB Miata LFX Wiring	victorzaccardo@gmail.com	Rev: 1
Size: A	Date:	KiCad E.D.A. kicad 7.0.6
		Id: 2/5

INTERIOR ENGINE BAY

J13	A_16	
	B_16	104 FUEL PUMP SWITCHED POS
	C_16	
	D_16	
	E_16	
	F_16	
	G_16	
	H_16	2500 CAN HIGH
	J_16	2501 CAN LOW
	K_16	116 KILL SWITCH POS
	L_16	
	M_16	
	N_16	1274 THROTTLE 5V REF 3
	P_16	1161 THROTTLE SIG 1
	R_16	1271 THROTTLE LOW REF 1
	S_16	1164 THROTTLE 5V REF 2
	T_16	1162 THROTTLE SIG 2
	U_16	1272 THROTTLE LOW REF 2
	V_16	
	W_16	419 MIL, CHECK ENG LIGHT
	X_16	112 A/C CLUTCH SIGNAL

AMPHENOL DURAMATE ADHP (PLASTIC) CONNECTOR
 MATING DURABILITY 100 CYCLES
 SIZE 12\16 CONTACTS RATED FOR 25A\13A

INLINE HARNESS SHELL: AHDP06-24-21SR-WTA
 90° BACKSHELL: AHDPBS-011-2405

SIZE 16 CONTACT MACHINED NICKEL-PLATED SOCKET:
 14 AWG: AT62-209-16141
 16-20 AWG: AT62-201-16141 <--
 22-24 AWG: AT62-201-16141-22

SIZE 16 CONTACT MACHINED GOLD-PLATED SOCKET:
 14 AWG: AT62-209-1631
 16-20 AWG: AT62-201-1631
 22-24 AWG: AT62-201-1631-22

SIZE 16 SEALING PLUG: A114017
 SIZE 16 CONTACT REMOVAL TOOL: AT11-310-1605

SIZE 12 CONTACT MACHINED NICKEL-PLATED SOCKET:
 12-14 AWG: AT62-203-12141 <--
 SIZE 12 CONTACT MACHINED GOLD-PLATED SOCKET:
 12-14 AWG: AT62-210-1231

SIZE 12 SEALING PLUG: A114017
 SIZE 12 CONTACT REMOVAL TOOL: AT11-337-1205

BLUE PCM
 CONNECTOR
 K20_X1
 -38
 ADD PIN TO
 CONNECTOR

FLEX FUEL
 SIGNAL
 115

J12
 1
 2
 3

GND

103
 ENG CTRL RLY

13519047 (15326808)
 Delphi GT 150 3 Way
 Sealed Female Connector

FLEX FUEL SENSOR:
 CONTINENTAL PN:
 Compact: 13577429
 With mounting holes and short fuel fittings: 13577379
 With mounting holes and long fuel fittings: 13577394
 ALL SENSORS ARE IDENTICAL, JUST DIFFERENT PACKAGING

Sheet: /LFX/
 File: LFX.kicad_sch

Title: LFX HARNESS MODIFICATIONS SCHEMATIC

NB Miata LFX Wiring		victorzaccardo@gmail.com	Rev: 1
Size: A	Date:	KiCad E.D.A. kicad 7.0.6	Id: 4/5

INTERIOR ENGINE BAY

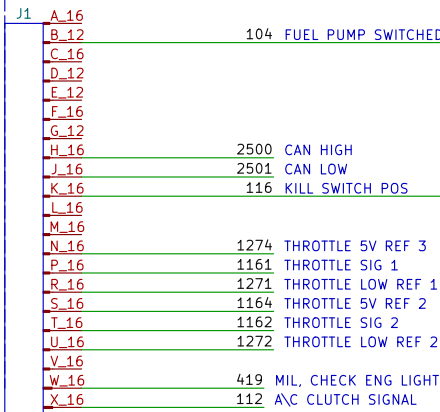

RUN 12AWG FROM BULKHEAD CON. TO FUEL PUMP. SPLICE INTO STOCK WIRING 6" BEFORE CONNECTOR. LEAVE 8" 12AWG SERVICE LOOP ON PUMP END



RUN 12AWG GROUND WIRE TO CHASSIS BEHIND DRIVERS SEAT

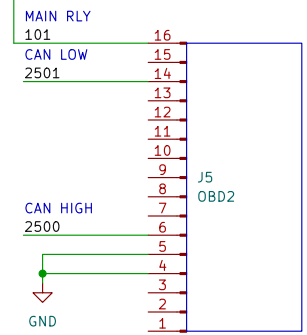
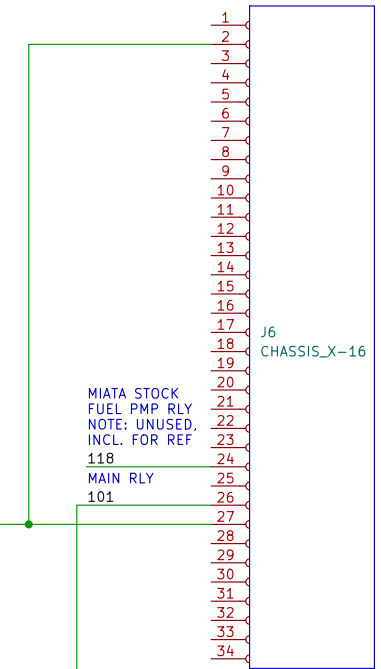
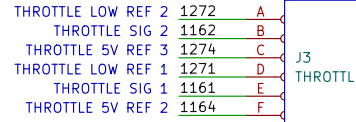
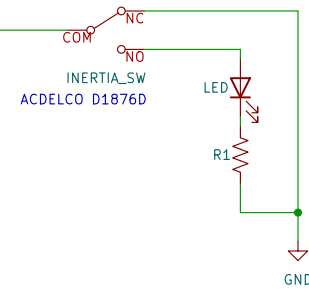

AMPHENOL DURAMATE ADHP (PLASTIC) CONNECTOR MATING DURABILITY 100 CYCLES SIZE 12X16 CONTACTS RATED FOR 25A/13A

FLANGE MOUNT SHELL: AHDP02-24-21PR-WTA TIE WRAP BACKSHELL: AHDPB5-0406-001

SIZE 16 CONTACT MACHINED NICKEL-PLATED PIN:
 14 AWG: AT60-215-16141
 16-20 AWG: AT60-202-16141 <---
 22-24 AWG: AT60-202-16141-22

SIZE 16 CONTACT MACHINED GOLD-PLATED PIN:
 14 AWG: AT60-215-1631
 16-20 AWG: AT60-202-1631
 22-24 AWG: AT60-202-1631-22

SIZE 16 SEALING PLUG: A114017
 SIZE 16 CONTACT REMOVAL TOOL: AT11-310-1605

SIZE 12 CONTACT MACHINED NICKEL-PLATED PIN:
 10-12 AWG: AT60-204-12141-10
 12-14 AWG: AT60-204-12141 <---

SIZE 12 CONTACT MACHINED GOLD-PLATED PIN:
 12-14 AWG: AT60-220-1231
 SIZE 12 SEALING PLUG: A114017
 SIZE 12 CONTACT REMOVAL TOOL: AT11-337-1205

DuraKote™ AHDA/ADHP Series - Part Numbering Sequence

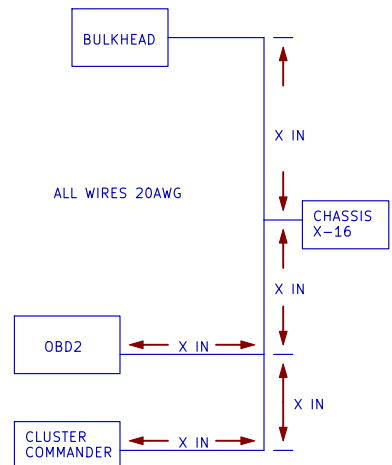
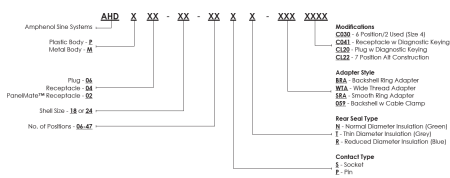

CLUSTER COMMANDER WIRING GAGE CLUSTER CONNECTORS SHOWN

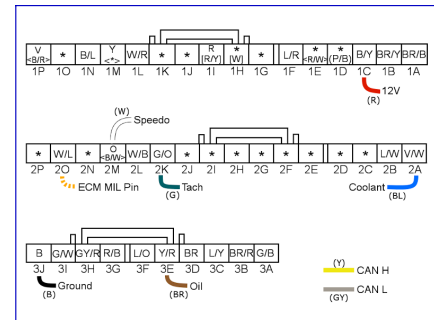

Sheet: /NEW_INT/
 File: NEW_INT.kicad_sch

Title: NEW INTERIOR HARNESS

NB Miata LFX Wiring		victorzaccardo@gmail.com	Rev: 1
Size: A	Date:	KiCad E.D.A. kicad 7.0.6	Id: 5/5